

## CARACTÉRISTIQUES

- Un avant-trou est nécessaire ; le filetage du matériau de support s'effectue durant l'installation de l'ancrage.
- Utilisable pour des charges hautes.
- Apte pour 2 profondeurs d'installation et même 3 avec le Ø10.
- Fixations structurales dans le béton fissuré et non fissuré.
- Se conformer au guide VdS CEA 4001 :2021-01(07) "Guidelines for sprinklers systems. Planning and installation"
- Conçu pour le béton fissuré et non fissuré.
- Utiliser pour les charges statiques ou quasi-statiques.
- Installation facile.
- Installation directe à travers le trou de la plaque d'ancrage.
- Peut se démonter, en laissant la surface diaphane.
- Variété de longueurs et métriques, flexibilité dans l'assemblage
- VdS disponible de Ø6 à Ø18
- Disponible en INDEXcal

## MATÉRIAU BASE



## GAMME DE MESURES

Ø5 - Ø18

## CONDITIONNEMENT DU TROU



SEC

HUMIDE

INONDÉ

**CHARGES MAXIMALES RECOMMANDÉES  
A LA TRACTION DANS LE BETON FISSURE  
ET NON FISSURE**  
[kg]

## APPLICATION

- Fixations structurales en béton fissuré et non fissuré
- Vitrages, fenêtres et vitrines.
- Étagères et racks
- Installation de balustrades et rampes en intérieurs
- Fixation de structures en bois dans béton

## EVALUATIONS





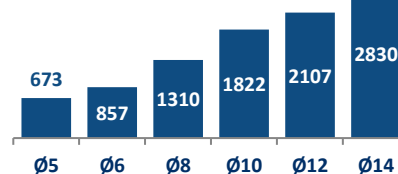











TH



## EXEMPLES D'APPLICATION



1. GAMME						
ITEM	CODE	SIZES	PHOTO	DESCRIPTION	MATÉRIAU	COUVRANT
1	THE	Ø5 - Ø18		Tête hexagonale à collerette	Acier au carbone estampé, ATLANTIS revêtement	
2	TFE	Ø5 - Ø18		Tête hexagonale à collerette	Acier au carbone estampé, zingué ≥ 5 µm	
3	TFN	Ø14		Tête hexagonale	Acier au carbone estampé, zingué ≥ 5 µm	
4	THA	Ø5 - Ø10		Fraisée, creux hexalobulaire	Acier au carbone estampé, ATLANTIS revêtement	
5	THT	Ø6		Tête bombée, empreinte hexalobulaire	Acier au carbone estampé, ATLANTIS revêtement	
6	THP	Ø5 - Ø8		Tête ronde, empreinte hexalobulaire	Acier au carbone estampé, ATLANTIS revêtement	
7	TFF	Ø6		Filetage femelle (fixation de tiges)	Acier au carbone estampé, zingué ≥ 5 µm	
8	TFM	Ø6		Filetage mâle	Acier au carbone estampé, zingué ≥ 5 µm	
9	TFS	Ø6 - Ø10		Tête filetée	Acier au carbone estampé, zingué ≥ 5 µm	

## 2. DONNÉES D'INSTALLATION

### 2.1. PLAN D'INSTALLATION

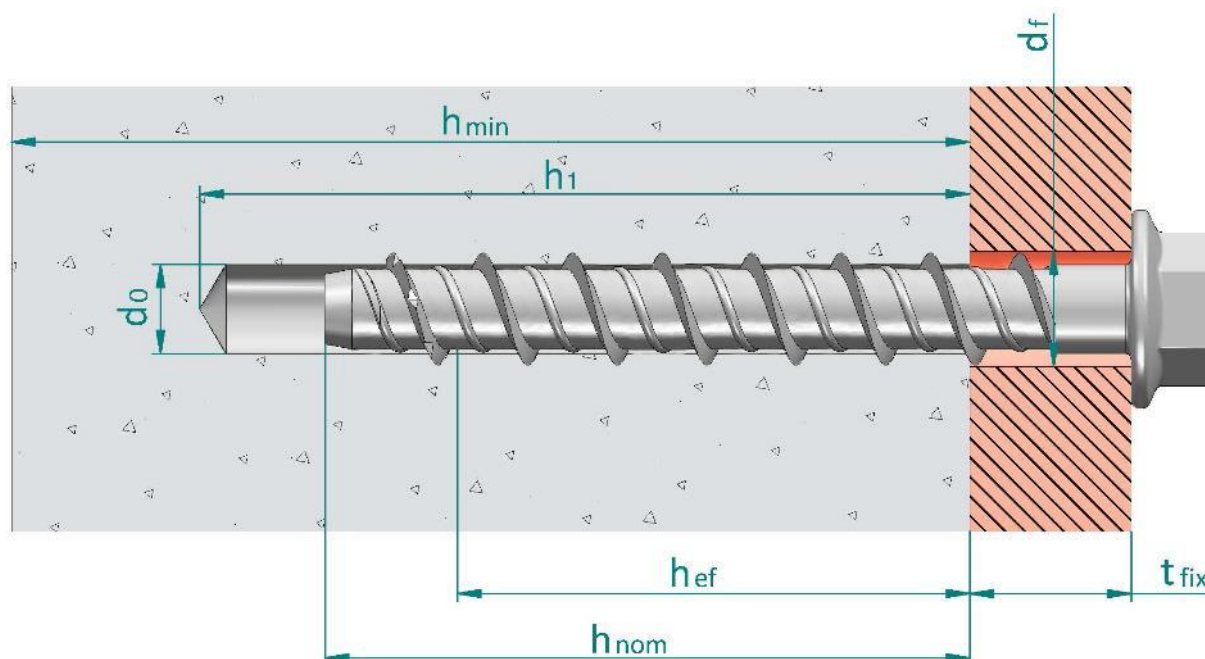

- d<sub>0</sub>: Diamètre du foret
- d<sub>f</sub>: Diamètre du trou d'épaisseur à fixer
- h<sub>ef</sub>: Profondeur effective
- h<sub>1</sub>: Profondeur du trou foré
- h<sub>nom</sub>: Profondeur d'installation
- h<sub>min</sub>: Epaisseur minimale du béton
- t<sub>fix</sub>: Épaisseur à fixer

### 2.2. GÉOMÉTRIE

DIAMÈTRE	[mm]	Ø5	Ø6	Ø8	Ø10	Ø12	Ø14	Ø18
TYPE	[TH/TF]	E, A, P	E, A, P, T, F, M, S	E, A, P, S	E, S	E	E, N	E
d <sub>1</sub> : Diamètre extérieur du filetage	[mm]	6,30	7,35	10,45	12,55	14,55	16,65	20,65
d <sub>2</sub> : Diamètre intérieur du filetage	[mm]	4,90	5,75	7,68	9,57	11,37	13,27	17,26
d <sub>3</sub> : Diamètre d'axe	[mm]	5,09	5,95	8,20	10,14	12,10	14,00	17,92
d <sub>k</sub> : Diamètre de rondelle	[mm]	11,50	14,00	17,00	20,00	25,00	28,00	37,00

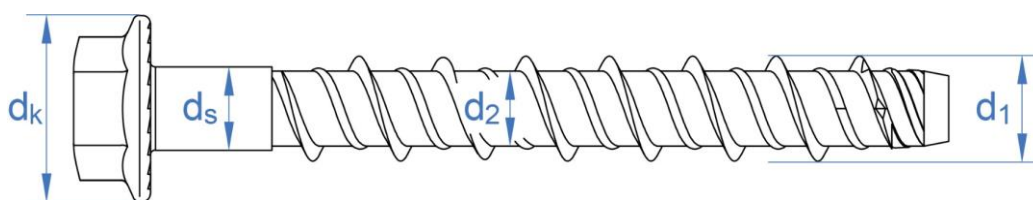

2.3. SEISMIC LOAD ASSESSMENT

Famille	Code	Dimension	Evaluation	C1	C2	Famille	Code	Dimension	Evaluation	C1	C2
[--]	[--]	[--]	ETA	[--]	[--]	[--]	[--]	[--]	ETA	[--]	[--]
THE	THE05040	Ø5 x 40	✓*	--	--	TFE	TFE05040	Ø5 x 40	✓*	--	--
	THE05050	Ø5 x 50	✓*	--	--		TFE05050	Ø5 x 50	✓*	--	--
	THE05060	Ø5 x 60	✓*	--	--		TFE05060	Ø5 x 60	✓*	--	--
	THE05080	Ø5 x 80	✓*	--	--		TFE05080	Ø5 x 80	✓*	--	--
	THE05100	Ø5 x 100	✓*	--	--		TFE05100	Ø5 x 100	✓*	--	--
	THE06040	Ø6 x 40	✓	--	--		TFE06040	Ø6 x 40	✓	--	--
	THE06050	Ø6 x 50	✓	✓	--		TFE06050	Ø6 x 50	✓	✓	--
	THE06060	Ø6 x 60	✓	✓	--		TFE06060	Ø6 x 60	✓	✓	--
	THE06070	Ø6 x 70	✓	✓	--		TFE06070	Ø6 x 70	✓	✓	--
	THE06080	Ø6 x 80	✓	✓	--		TFE06080	Ø6 x 80	✓	✓	--
	THE06100	Ø6 x 100	✓	✓	--		TFE06100	Ø6 x 100	✓	✓	--
	THE06120	Ø6 x 120	✓	✓	--		TFE06120	Ø6 x 120	✓	✓	--
	THE08055	Ø8 x 55	✓	✓	✓		TFE08055	Ø8 x 55	✓	✓	✓
	THE08060	Ø8 x 60	✓	✓	✓		TFE08060	Ø8 x 60	✓	✓	✓
	THE08070	Ø8 x 70	✓	✓	✓		TFE08070	Ø8 x 70	✓	✓	✓
	THE08080	Ø8 x 80	✓	✓	✓		TFE08080	Ø8 x 80	✓	✓	✓
	THE08090	Ø8 x 90	✓	✓	✓		TFE08090	Ø8 x 90	✓	✓	✓
	THE08100	Ø8 x 100	✓	✓	✓		TFE08100	Ø8 x 100	✓	✓	✓
	THE08110	Ø8 x 110	✓	✓	✓		TFE08110	Ø8 x 110	✓	✓	✓
	THE08120	Ø8 x 120	✓	✓	✓		TFE08120	Ø8 x 120	✓	✓	✓
	THE08140	Ø8 x 140	✓	✓	✓		TFE08140	Ø8 x 140	✓	✓	✓
	THE10060	Ø10 x 60	✓	--	--		TFE10060	Ø10 x 60	✓	--	--
	THE10070	Ø10 x 70	✓	--	--		TFE10070	Ø10 x 70	✓	--	--
	THE10080	Ø10 x 80	✓	--	--		TFE10080	Ø10 x 80	✓	--	--
	THE10090	Ø10 x 90	✓	✓	✓		TFE10090	Ø10 x 90	✓	✓	✓
	THE10100	Ø10 x 100	✓	✓	✓		TFE10100	Ø10 x 100	✓	✓	✓
	THE10120	Ø10 x 120	✓	✓	✓		TFE10120	Ø10 x 120	✓	✓	✓
	THE10140	Ø10 x 140	✓	✓	✓		TFE10140	Ø10 x 140	✓	✓	✓
	THE12080	Ø12 x 80	✓	--	--		TFE12080	Ø12 x 80	✓	--	--
	THE12090	Ø12 x 90	✓	--	--		TFE12090	Ø12 x 90	✓	--	--
	THE12110	Ø12 x 110	✓	✓	✓		TFE12110	Ø12 x 110	✓	✓	✓
	THE12130	Ø12 x 130	✓	✓	✓		TFE12130	Ø12 x 130	✓	✓	✓
	THE12150	Ø12 x 150	✓	✓	✓		TFE12150	Ø12 x 150	✓	✓	✓
	THE14080	Ø14 x 80	✓	--	--		TFE14080	Ø14 x 80	✓	--	--
	THE14100	Ø14 x 100	✓	--	--		TFE14100	Ø14 x 100	✓	--	--
	THE14120	Ø14 x 120	✓	✓	✓		TFE14120	Ø14 x 120	✓	✓	✓
THE14130	Ø14 x 130	✓	✓	✓	TFE14130	Ø14 x 130	✓	✓	✓		
THE14140	Ø14 x 140	✓	✓	✓	TFE14140	Ø14 x 140	✓	✓	✓		
THE14160	Ø14 x 160	✓	✓	✓	TFE14160	Ø14 x 160	✓	✓	✓		
THE18100	Ø18 x 100	✓	--	--	TFE18100	Ø18 x 100	✓	--	--		
THE18130	Ø18 x 130	✓	--	--	TFE18130	Ø18 x 130	✓	--	--		
THE18160	Ø18 x 160	✓	✓	✓	TFE18160	Ø18 x 160	✓	✓	✓		
THE18180	Ø18 x 180	✓	✓	✓	TFE18180	Ø18 x 180	✓	✓	✓		
THE18200	Ø18 x 200	✓	✓	✓	TFE18200	Ø18 x 200	✓	✓	✓		
TFN	TFN14080	Ø14 x 80	--	--	--	THP05040	Ø5 x 40	✓*	--	--	
THT	THT06040	Ø6 x 40	✓	--	--	THP05060	Ø5 x 60	✓*	--	--	
	THT06050	Ø6 x 50	✓	✓	--	THP06040	Ø6 x 40	✓	--	--	
	THT06060	Ø6 x 60	✓	✓	--	THP06050	Ø6 x 50	✓	✓	--	
TFF	TFF06035	Ø6 x 35 (M8-M10)	✓	--	--	THP06060	Ø6 x 60	✓	✓	--	
	TFF06055	Ø6 x 55 (M8-M10)	✓	✓	--	THP06080	Ø6 x 80	✓	✓	--	
TFM	TFM06035	Ø6 x 35 (M8)	✓	--	--	THP06100	Ø6 x 100	✓	✓	--	
	TFM06055	Ø6 x 55 (M10)	✓	✓	--	THP08060	Ø8 x 60	✓	✓	✓	
						THP08080	Ø8 x 80	✓	✓	✓	

Famille	Code	Dimension	Evaluation	C1	C2	Famille	Code	Dimension	Evaluation	C1	C2
[--]	[--]	[--]	ETA	[--]	[--]	[--]	[--]	[--]	ETA	[--]	[--]
THA	THA05040	Ø5 x 40	✓*	--	--	TFS	TFS06100	Ø6 x 100 (M8)	✓	✓	--
	THA05060	Ø5 x 60	✓*	--	--		TFS06120	Ø6 x 120 (M8)	✓	✓	--
	THA05080	Ø5 x 80	✓*	--	--		TFS08110	Ø8 x 110 (M10)	✓	✓	✓
	THA05100	Ø5 x 100	✓*	--	--		TFS08130	Ø8 x 130 (M10)	✓	✓	✓
	THA06045	Ø6 x 45	✓	--	--		TFS10120	Ø10 x 120 (M12)	✓	--	--
	THA06050	Ø6 x 50	✓	✓	--		TFS10140	Ø10 x 140 (M12)	✓	--	--
	THA06060	Ø6 x 60	✓	✓	--						
	THA06080	Ø6 x 80	✓	✓	--						
	THA06120	Ø6 x 120	✓	✓	--						
	THA06140	Ø6 x 140	✓	✓	--						
	THA08060	Ø8 x 60	✓	✓	✓						
	THA08080	Ø8 x 80	✓	✓	✓						
	THA08100	Ø8 x 100	✓	✓	✓						
	THA08120	Ø8 x 120	✓	✓	✓						
	THA10100	Ø10 x 100	✓	✓	✓						
	THA10120	Ø10 x 120	✓	✓	✓						

## 3. PARAMETRES D'INSTALLATION

Paramètres généraux d'installation				Profondeur d'installation standard												Profondeur d'installation réduite											
Famille	Code	Dimension	Evaluation	Diamètre du foret	Diamètre du trou d'épaisseur à fixer	Version du tete	Couple de serrage maximal	Distance minimale entre axes	Distance minimale au bord	Épaisseur minimale du béton	Profondeur du trou foré	Profondeur d'installation	Profondeur effective	Épaisseur à fixer	Distance minimale entre axes (cône)	Distance critique au bord (cône)	Distance minimale entre axes (fissuration)	Distance critique au bord (fissuration)	Épaisseur minimale du béton	Profondeur du trou foré	Profondeur d'installation	Profondeur effective	Épaisseur à fixer	Distance minimale entre axes (cône)	Distance critique au bord (cône)	Distance minimale entre axes (fissuration)	Distance critique au bord (fissuration)
[--]	[--]	[--]	ETA	d <sub>0</sub> [mm]	d <sub>r</sub> [mm]	SW/Tx [--]	T <sub>inst</sub> [Nm]	S <sub>min</sub> [mm]	C <sub>min</sub> [mm]	h <sub>min</sub> [mm]	h <sub>1</sub> [mm]	h <sub>nom</sub> [mm]	h <sub>ef</sub> [mm]	t <sub>fix</sub> [mm]	S <sub>cr,N</sub> [mm]	C <sub>cr,N</sub> [mm]	S <sub>cr,sp</sub> [mm]	C <sub>cr,sp</sub> [mm]	h <sub>min</sub> [mm]	h <sub>1</sub> [mm]	h <sub>nom</sub> [mm]	h <sub>ef</sub> [mm]	t <sub>fix</sub> [mm]	S <sub>cr,N</sub> [mm]	C <sub>cr,N</sub> [mm]	S <sub>cr,sp</sub> [mm]	C <sub>cr,sp</sub> [mm]
THE	THE05040	Ø5 x 40	✓*	5	8	SW 8	8	35	35	--	--	--	--	--	--	--	--	--	80	45	35	26,5	5	80	40	80	40
	THE05050	Ø5 x 50	✓*			SW 8				5																	
	THE05060	Ø5 x 60	✓*			SW 8				15																	
	THE05080	Ø5 x 80	✓*			SW 8				35																	
	THE05100	Ø5 x 100	✓*			SW 8				55																	
	THE06040	Ø6 x 40	✓	6	9	SW 10	10	35	35	--	--	--	--	--	--	--	--	--	100	45	35	26,0	5	78	39	90	45
	THE06050	Ø6 x 50	✓			SW 10				15																	
	THE06060	Ø6 x 60	✓			SW 10				25																	
	THE06070	Ø6 x 70	✓			SW 10				35																	
	THE06080	Ø6 x 80	✓			SW 10				45																	
	THE06100	Ø6 x 100	✓			SW 10				65																	
	THE06120	Ø6 x 120	✓	SW 10	85																						
	THE08055	Ø8 x 55	✓	8	12	SW 13	20	35	35	--	--	--	--	--	--	--	--	--	100	60	50	37,5	5	113	57	130	65
	THE08060	Ø8 x 60	✓			SW 13				10																	
	THE08070	Ø8 x 70	✓			SW 13				20																	
	THE08080	Ø8 x 80	✓			SW 13				30																	
	THE08090	Ø8 x 90	✓			SW 13				40																	
	THE08100	Ø8 x 100	✓			SW 13				50																	
	THE08110	Ø8 x 110	✓			SW 13				60																	
	THE08120	Ø8 x 120	✓			SW 13				70																	
	THE08140	Ø8 x 140	✓			SW 13				90																	
	THE10060	Ø10 x 60	✓			10				14	SW 15	30	50	40	--	--	--	--					--				
	THE10070	Ø10 x 70	✓	SW 15	15																						
	THE10080	Ø10 x 80	✓	SW 15	25																						
	THE10090	Ø10 x 90	✓	SW 15	35																						
	THE10100	Ø10 x 100	✓	SW 15	45																						
	THE10120	Ø10 x 120	✓	SW 15	65																						
	THE10140	Ø10 x 140	✓	SW 15	85																						

\*Ø5 Approuvé uniquement pour un emploi sur le béton et sur dalles alvéolaires préfabriquées pour des systèmes non-structuraux redondants

Paramètres généraux d'installation									Profondeur d'installation standard									Profondeur d'installation réduite									
Famille	Code	Dimension	Evaluation	Diamètre du foret	Diamètre du trou d'épaisseur à fixer	Version du tete	Couple de serrage maximal	Distance minimale entre axes	Distance minimale au bord	Épaisseur minimale du béton	Profondeur du trou foré	Profondeur d' installation	Profondeur effective	Épaisseur à fixer	Distance minimale entre axes (cône)	Distance critique au bord (cône)	Distance minimale entre axes (fissuration)	Distance critique au bord (fissuration)	Épaisseur minimale du béton	Profondeur du trou foré	Profondeur d' installation	Profondeur effective	Épaisseur à fixer	Distance minimale entre axes (cône)	Distance critique au bord (cône)	Distance minimale entre axes (fissuration)	Distance critique au bord (fissuration)
[--]	[--]	[--]	ETA	d <sub>0</sub> [mm]	d <sub>f</sub> [mm]	SW/Tx [--]	T <sub>inst</sub> [Nm]	S <sub>min</sub> [mm]	C <sub>min</sub> [mm]	h <sub>min</sub> [mm]	h <sub>1</sub> [mm]	h <sub>nom</sub> [mm]	h <sub>ef</sub> [mm]	t <sub>fix</sub> [mm]	S <sub>cr,N</sub> [mm]	C <sub>cr,N</sub> [mm]	S <sub>cr,sp</sub> [mm]	C <sub>cr,sp</sub> [mm]	h <sub>min</sub> [mm]	h <sub>1</sub> [mm]	h <sub>nom</sub> [mm]	h <sub>ef</sub> [mm]	t <sub>fix</sub> [mm]	S <sub>cr,N</sub> [mm]	C <sub>cr,N</sub> [mm]	S <sub>cr,sp</sub> [mm]	C <sub>cr,sp</sub> [mm]
THE	THE12080	Ø12 x 80	✓	12	16	SW 18	50	75	45	--	--	--	--	--	--	--	--	--	120	90	75	58,0	5	174	87	190	95
	THE12090	Ø12 x 90	✓			15																					
	THE12110	Ø12 x 110	✓			35																					
	THE12130	Ø12 x 130	✓			55																					
	THE12150	Ø12 x 150	✓			75																					
	THE14080	Ø14 x 80	✓	14	18	SW 21	70	80	50	--	--	--	--	--	--	--	--	--	120	90	75	58,0	5	174	87	190	95
	THE14100	Ø14 x 100	✓			25																					
	THE14120	Ø14 x 120	✓			45																					
	THE14130	Ø14 x 130	✓			55																					
	THE14140	Ø14 x 140	✓			65																					
	THE14160	Ø14 x 160	✓	85																							
	THE18100	Ø18 x 100	✓	18	22	SW 24	90	90	55	--	--	--	--	--	--	--	--	--	140	110	90	69,5	10	209	105	230	115
	THE18130	Ø18 x 130	✓			40																					
	THE18160	Ø18 x 160	✓			70																					
	THE18180	Ø18 x 180	✓			90																					
THE18200	Ø18 x 200	✓	110																								

Paramètres généraux d'installation										Profondeur d'installation standard								Profondeur d'installation réduite																																							
Famille	Code	Dimension	Evaluation	Diamètre du foret	Diamètre du trou d'épaisseur à fixer	Version du tete	Couple de serrage maximal	Distance minimale entre axes	Distance minimale au bord	Epaisseur minimale du béton	Profondeur du trou foré	Profondeur d' installation	Profondeur effective	Épaisseur à fixer	Distance minimale entre axes (cône)	Distance critique au bord (cône)	Distance minimale entre axes	Distance critique au bord (fissuration)	Epaisseur minimale du béton	Profondeur du trou foré	Profondeur d' installation	Profondeur effective	Épaisseur à fixer	Distance minimale entre axes (cône)	Distance critique au bord (cône)	Distance minimale entre axes	Distance critique au bord (fissuration)																														
[--]	[--]	[--]	ETA	d <sub>0</sub>	d <sub>f</sub>	SW/Tx	T <sub>inst</sub>	S <sub>min</sub>	C <sub>min</sub>	h <sub>min</sub>	h <sub>1</sub>	h <sub>nom</sub>	h <sub>ef</sub>	t <sub>fix</sub>	S <sub>cr,N</sub>	C <sub>cr,N</sub>	S <sub>cr,sp</sub>	C <sub>cr,sp</sub>	h <sub>min</sub>	h <sub>1</sub>	h <sub>nom</sub>	h <sub>ef</sub>	t <sub>fix</sub>	S <sub>cr,N</sub>	C <sub>cr,N</sub>	S <sub>cr,sp</sub>	C <sub>cr,sp</sub>																														
				[mm]	[mm]	[--]	[Nm]	[mm]	[mm]	[mm]	[mm]	[mm]	[mm]	[mm]	[mm]	[mm]	[mm]	[mm]	[mm]	[mm]	[mm]	[mm]	[mm]	[mm]	[mm]	[mm]	[mm]	[mm]																													
TFE	TFE05040	Ø5 x 40	✓*	5	8	SW 8	8	35	35	--	--	--	--	--	--	--	--	--	80	55	45	35,0	--	105	53	105	53	80	45	35	26,5	5	80	40	80	40																					
	TFE05050	Ø5 x 50	✓*			SW 8				5																																															
	TFE05060	Ø5 x 60	✓*			SW 8				15																																															
	TFE05080	Ø5 x 80	✓*			SW 8				35																																															
	TFE05100	Ø5 x 100	✓*			SW 8				55																																															
	TFE06040	Ø6 x 40	✓	6	9	SW 10	10	35	35	--	--	--	--	--	--	--	--	--	100	65	55	43,0	--	129	65	170	85	100	45	35	26,0	5	78	39	90	45																					
	TFE06050	Ø6 x 50	✓			SW 10				15																																															
	TFE06060	Ø6 x 60	✓			SW 10				25																																															
	TFE06070	Ø6 x 70	✓			SW 10				35																																															
	TFE06080	Ø6 x 80	✓			SW 10				45																																															
	TFE06100	Ø6 x 100	✓			SW 10				65																																															
	TFE06120	Ø6 x 120	✓			SW 10				85																																															
	TFE08055	Ø8 x 55	✓			8				12	SW 13	20	35	35	--	--	--	--					--									--					--	--	--	100	75	65	50,5	--	152	76	200	100	100	60	50	37,5	5	113	57	130	65
	TFE08060	Ø8 x 60	✓								SW 13				10																																										
	TFE08070	Ø8 x 70	✓								SW 13				20																																										
	TFE08080	Ø8 x 80	✓	SW 13	30																																																				
	TFE08090	Ø8 x 90	✓	SW 13	40																																																				
	TFE08100	Ø8 x 100	✓	SW 13	50																																																				
	TFE08110	Ø8 x 110	✓	SW 13	60																																																				
	TFE08120	Ø8 x 120	✓	SW 13	70																																																				
	TFE08140	Ø8 x 140	✓	SW 13	90																																																				
	TFE10060	Ø10 x 60	✓	10	14		SW 15	30	50		40				--	--	--	--	--	--	--	--	--	100	95	85	67,0	--	201	101	210	105	100	65	55	41,5	5	125	63					140									70				
	TFE10070	Ø10 x 70	✓			SW 15	15																																																		
	TFE10080	Ø10 x 80	✓			SW 15	25																																																		
	TFE10090	Ø10 x 90	✓			SW 15	35																																																		
	TFE10100	Ø10 x 100	✓			SW 15	45																																																		
	TFE10120	Ø10 x 120	✓			SW 15	65																																																		
	TFE10140	Ø10 x 140	✓			SW 15	85																																																		

\*Ø5 Approuvé uniquement pour un emploi sur le béton et sur dalles alvéolaires préfabriquées pour des systèmes non-structuraux redondants



## Paramètres généraux d'installation

## Profondeur d'installation standard

## Profondeur d'installation réduite

Familie	Code	Dimension	Evaluation	Diamètre du foret	Diamètre du trou d'épaisseur à fixer	Version du tete	Couple de serrage maximal	Distance minimale entre axes	Distance minimale au bord	Epaisseur minimale du béton	Profondeur du trou foré	Profondeur d' installation	Profondeur effective	Épaisseur à fixer	Distance minimale entre axes (cône)	Distance critique au bord (cône)	Distance minimale entre axes (fissuration)	Distance critique au bord (fissuration)	Epaisseur minimale du béton	Profondeur du trou foré	Profondeur d' installation	Profondeur effective	Épaisseur à fixer	Distance minimale entre axes (cône)	Distance critique au bord (cône)	Distance minimale entre axes (fissuration)	Distance critique au bord (fissuration)
				d <sub>0</sub>	d <sub>f</sub>																						
[--]	[--]	[--]	ETA	[mm]	[mm]	[--]	[Nm]	[mm]	[mm]	[mm]	[mm]	[mm]	[mm]	[mm]	[mm]	[mm]	[mm]	[mm]	[mm]	[mm]	[mm]	[mm]	[mm]	[mm]	[mm]	[mm]	[mm]
TFE	TFE12080	Ø12 x 80	✓	12	16	SW 18	50	75	45	--	--	--	--	--	--	--	--	120	90	75	58,0	5	174	87	190	95	
	TFE12090	Ø12 x 90	✓			SW 18				--	--	--	--	--	15												
	TFE12110	Ø12 x 110	✓	SW 18	5	251	126	220	110	35																	
	TFE12130	Ø12 x 130	✓	SW 18	25	251	126	220	110	55																	
	TFE12150	Ø12 x 150	✓	SW 18	45	251	126	220	110	75																	
	TFE14080	Ø14 x 80	✓	14	18	SW 21	70	80	50	--	--	--	--	--	--	--	--	120	90	75	58,0	5	174	87	190	95	
	TFE14100	Ø14 x 100	✓			SW 21				--	--	--	--	--	25												
	TFE14120	Ø14 x 120	✓			SW 21				5	276	138	230	115	45												
	TFE14130	Ø14 x 130	✓			SW 21				15	276	138	230	115	55												
	TFE14140	Ø14 x 140	✓			SW 21				25	276	138	230	115	65												
	TFE14160	Ø14 x 160	✓			SW 21				45	276	138	230	115	85												
	TFE18100	Ø18 x 100	✓	18	22	SW 24	90	90	55	--	--	--	--	--	--	--	--	140	110	90	69,5	10	209	105	230	115	
TFE18130	Ø18 x 130	✓	SW 24			--				--	--	--	--	40													
TFE18160	Ø18 x 160	✓	SW 24			20				336	168	350	175	70													
TFE18180	Ø18 x 180	✓	SW 24			40				336	168	350	175	90													
TFE18200	Ø18 x 200	✓	SW 24			60				336	168	350	175	110													
TFN	TFN14080	Ø14 x 80	✓			14				18	SW 24	70	80	50	--	--	--					--					--

Paramètres généraux d'installation										Profondeur d'installation standard								Profondeur d'installation réduite										
Familie	Code	Dimension	Evaluation	Diamètre du foret	Diamètre du trou d'épaisseur à fixer	Version du tete	Couple de serrage maximal	Distance minimale entre axes	Distance minimale au bord	Epaisseur minimale du béton	Profondeur du trou foré	Profondeur d'installation	Profondeur effective	Épaisseur à fixer	Distance minimale entre axes (cône)	Distance critique au bord (cône)	Distance minimale entre axes (fissuration)	Distance critique au bord (fissuration)	Epaisseur minimale du béton	Profondeur du trou foré	Profondeur d'installation	Profondeur effective	Épaisseur à fixer	Distance minimale entre axes (cône)	Distance critique au bord (cône)	Distance minimale entre axes (fissuration)	Distance critique au bord (fissuration)	
				d <sub>0</sub> [mm]	d <sub>f</sub> [mm]																							SW/Tx [--]
THA	THA05040	Ø5 x 40	✓*	5	8	TX25	8	35	35	80	55	45	35,0	15	105	53	105	53	80	45	35	26,5	5	80	40	80	40	
	THA05060	Ø5 x 60	✓*			TX25																						25
	THA05080	Ø5 x 80	✓*			TX25																						45
	THA05100	Ø5 x 100	✓*			TX25																						65
	THA06045	Ø6 x 45	✓	6	9	TX30	10	35	35	100	65	55	43,0	25	129	65	170	85	100	45	35	26,0	10	78	39	90	45	
	THA06050	Ø6 x 50	✓			TX30																						15
	THA06060	Ø6 x 60	✓			TX30																						25
	THA06080	Ø6 x 80	✓			TX30																						45
	THA06120	Ø6 x 120	✓			TX30																						85
	THA06140	Ø6 x 140	✓			TX30																						105
	THA08060	Ø8 x 60	✓	8	12	TX45	20	35	35	100	75	65	50,5	15	152	76	200	100	100	60	50	37,5	10	113	57	130	65	
	THA08080	Ø8 x 80	✓			TX45																						30
	THA08100	Ø8 x 100	✓			TX45																						50
	THA08120	Ø8 x 120	✓			TX45																						70
THA10100	Ø10 x 100	✓	10	14	TX50	30	50	40	135	95	85	67,0	15	201	101	210	105	100	65	55	41,5	45	125	63	140	70		
THA10120	Ø10 x 120	✓			TX50																						65	
THT	THT06040	Ø6 x 40	✓	6	9	TX30	10	35	35	100	65	55	43,0	5	129	65	170	85	100	45	35	26,0	15	78	39	90	45	
	THT06050	Ø6 x 50	✓			TX30																						25
	THT06060	Ø6 x 60	✓			TX30																						25
THP	THP05040	Ø5 x 40	✓*	5	8	TX30	8	35	35	80	55	45	35,0	15	105	53	105	53	80	45	35	26,5	5	80	40	80	40	
	THP05060	Ø5 x 60	✓*			TX30																						25
	THP06040	Ø6 x 40	✓	6	9	TX40	10	35	35	100	65	55	43,0	5	129	65	170	85	100	45	35	26,0	15	78	39	90	45	
	THP06050	Ø6 x 50	✓			TX40																						25
	THP06060	Ø6 x 60	✓			TX40																						45
	THP06100	Ø6 x 100	✓			TX40																						65
	THP08060	Ø8 x 60	✓	8	12	TX45	20	35	35	100	75	65	50,5	15	152	76	200	100	100	60	50	37,5	10	113	57	130	65	
	THP08080	Ø8 x 80	✓			TX45																						30

\*Ø5 Approuvé uniquement pour un emploi sur le béton et sur dalles alvéolaires préfabriquées pour des systèmes non-structuraux redondants

Paramètres généraux d'installation										Profondeur d'installation standard										Profondeur d'installation réduite									
Famille	Code	Dimension	Evaluation	Diamètre du foret	Diamètre du trou d'épaisseur à fixer	Version du tete	Couple de serrage maximal	Distance minimale entre axes	Distance minimale au bord	Epaisseur minimale du béton	Profondeur du trou foré	Profondeur d' installation	Profondeur effective	Épaisseur à fixer	Distance minimale entre axes (cône)	Distance critique au bord (cône)	Distance minimale entre axes (fissuration)	Distance critique au bord (fissuration)	Epaisseur minimale du béton	Profondeur du trou foré	Profondeur d' installation	Profondeur effective	Épaisseur à fixer	Distance minimale entre axes (cône)	Distance critique au bord (cône)	Distance minimale entre axes (fissuration)	Distance critique au bord (fissuration)		
[--]	[--]	[--]	ETA	d <sub>0</sub> [mm]	d <sub>f</sub> [mm]	SW/Tx [--]	T <sub>inst</sub> [Nm]	S <sub>min</sub> [mm]	C <sub>min</sub> [mm]	h <sub>min</sub> [mm]	h <sub>1</sub> [mm]	h <sub>nom</sub> [mm]	h <sub>ef</sub> [mm]	t <sub>fix</sub> [mm]	S <sub>cr,N</sub> [mm]	C <sub>cr,N</sub> [mm]	S <sub>cr,sp</sub> [mm]	C <sub>cr,sp</sub> [mm]	h <sub>min</sub> [mm]	h <sub>1</sub> [mm]	h <sub>nom</sub> [mm]	h <sub>ef</sub> [mm]	t <sub>fix</sub> [mm]	S <sub>cr,N</sub> [mm]	C <sub>cr,N</sub> [mm]	S <sub>cr,sp</sub> [mm]	C <sub>cr,sp</sub> [mm]		
TFF	TFF06035	∅6 x 35 (M8-M10)	✓	6	--	SW 13	10	35	35	--	--	--	--	--	--	--	--	--	100	45	35	26,0	--	78	39	90	45		
	TFF06055	∅6 x 55 (M8-M10)	✓			SW 13				100	65	55	43,0	--	129	65	170	85	--	--	--	--	--	--	--	--	--	--	--
TFM	TFM06035	∅6 x 35 (M8)	✓	6	--	SW 13	10	35	35	--	--	--	--	--	--	--	--	--	100	65	55	26,0	--	78	39	90	45		
	TFM06055	∅6 x 55 (M10)	✓			SW 13				100	65	55	43,0	--	129	65	170	85	--	--	--	--	--	--	--	--	--	--	--
TFS	TFS06100	∅6 x 100 (M8)	✓	6	9	SW 5	10	35	35	100	65	55	43,0	35	129	65	170	85	100	45	35	26,0	55	78	39	90	45		
	TFS06120	∅6 x 120 (M8)	✓			SW 5								75															
	TFS08110	∅8 x 110 (M10)	✓	8	12	SW 7	20	35	35	100	75	65	50,5	32	152	76	200	100	100	60	50	37,5	47	113	57	130	65		
	TFS08130	∅8 x 130 (M10)	✓			SW 7								52															
	TFS10120	∅10 x 120 (M12)	✓	10	14	SW 8	30	50	40	120	85	75	58,5	27	176	88	190	95	100	65	55	41,5	52	125	63	140	70		
	TFS10140	∅10 x 140 (M12)	✓			SW 8								47															

**4. PROCESSUS D'INSTALLATION****4.1. INSTALLATION DANS LE BÉTON****1. PERCER**

Vérifier que le béton est bien compact et sans pores significatifs.  
Admet des trous secs, humides ou inondés.  
Perçage en mode percussion ou marteau.  
Percer au diamètre et à la profondeur spécifiée.

**2. SOUFFLER ET NETTOYER**

Nettoyer le trou des restes de poussière et des fragments du perçage.  
Utiliser bombe d'air et brosse

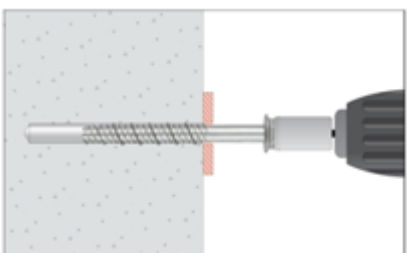
**3. INSTALLER**

Utiliser une clé à choc ou une clé dynamométrique ne dépassant pas les couples de serrage maximaux Timpact,max ou Tins,max respectivement.  
Connecter la douille d'installation ou la pointe hexagonal.  
Assembler la tête de la vis dans la douille/pointe.

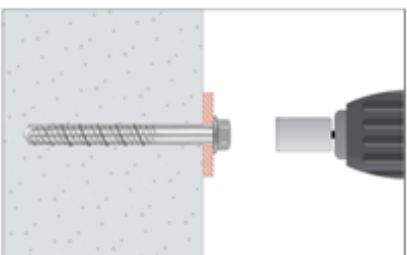
**4. APPLIQUER COUPLE DE SERRAGE**

Insérer la vis dans le trou avec une clé à choc ou une clé dynamométrique à travers la plaque d'ancrage jusqu'à ce que la tête soit en contact avec la plaque. La vis doit rester serrée après l'installation et ne doit plus être desserrée.

## 5. RÉSISTANCES

Les résistances dans le béton C20 / 25 pour un ancrage isolé sans effets de la distance au bord et des distances entre les ancrages sont indiquées dans le tableau suivant :

Les valeurs *soulignées et en italique* indiquent une défaillance de l'acier, les valeurs en **gras** indiquent une défaillance par le béton et le reste indique une défaillance par extraction.

1 KN ≈ 100 kg

### 5.1 RESISTANCES CHARACTERISTIQUES (APPLICATION STRUCTURELLE) [kN]

Paramètres généraux				Non-fissuré béton				Fissuré béton				
Familie	Code	Dimension	Evaluation	Traction $N_{Rk, ucr}$		Cisaillemen $V_{Rk, ucr}$		Traction $N_{Rk, cr}$		Cisaillemen $V_{Rk, cr}$		
			ETA	( $h_{ef, std}$ )	( $h_{ef, red}$ )	( $h_{ef, std}$ )	( $h_{ef, red}$ )	( $h_{ef, std}$ )	( $h_{ef, red}$ )	( $h_{ef, std}$ )	( $h_{ef, red}$ )	
THE	THE05040	Ø5 x 40	✓*	--	<b>6,71</b>	--	<b>6,71</b>	--	<b>4,70</b>	--	<b>4,70</b>	
	THE05050	Ø5 x 50	✓*									
	THE05060	Ø5 x 60	✓*									
	THE05080	Ø5 x 80	✓*		<b>10,19</b>	<b>6,71</b>	<i>8,19</i>	<b>6,71</b>	<b>7,13</b>	<b>4,70</b>	<b>7,13</b>	<b>4,70</b>
	THE05100	Ø5 x 100	✓*									
	THE06040	Ø6 x 40	✓	--		5,00	--	<i>12,53</i>	--	<b>4,57</b>	--	<b>9,36</b>
	THE06050	Ø6 x 50	✓	--								
	THE06060	Ø6 x 60	✓									
	THE06070	Ø6 x 70	✓									
	THE06080	Ø6 x 80	✓		<b>13,87</b>	5,00	<i>12,53</i>	<i>12,53</i>	<b>9,71</b>	<b>4,57</b>	<b>11,17</b>	<b>9,36</b>
	THE06100	Ø6 x 100	✓									
	THE06120	Ø6 x 120	✓									
	THE08055	Ø8 x 55	✓	--								
	THE08060	Ø8 x 60	✓	--		<b>11,30</b>	--	<i>19,57</i>	--	<b>7,91</b>	--	<b>14,23</b>
	THE08070	Ø8 x 70	✓									
	THE08080	Ø8 x 80	✓									
	THE08090	Ø8 x 90	✓									
	THE08100	Ø8 x 100	✓		<b>17,65</b>	<b>11,30</b>	<i>19,57</i>	<i>19,57</i>	<b>12,36</b>	<b>7,91</b>	<b>15,69</b>	<b>14,23</b>
	THE08110	Ø8 x 110	✓									
	THE08120	Ø8 x 120	✓									
	THE08140	Ø8 x 140	✓									
	THE10060	Ø10 x 60	✓	--			--		--		--	
	THE10070	Ø10 x 70	✓	--		<b>13,15</b>	--	<b>25,65</b>	--	<b>9,21</b>	--	<b>17,95</b>
	THE10080	Ø10 x 80	✓	--			--		--		--	
	THE10090	Ø10 x 90	✓									
	THE10100	Ø10 x 100	✓		<b>26,98</b>	<b>13,15</b>	<i>27,40</i>	<b>25,65</b>	<b>18,89</b>	<b>9,21</b>	<i>27,40</i>	<b>17,95</b>
	THE10120	Ø10 x 120	✓									
	THE10140	Ø10 x 140	✓									
	THE12080	Ø12 x 80	✓	--			--	<i>37,24</i>	--	<b>15,21</b>	--	<b>35,44</b>
	THE12090	Ø12 x 90	✓	--		<b>21,73</b>	--		--		--	
	THE12110	Ø12 x 110	✓									
	THE12130	Ø12 x 130	✓		<b>37,54</b>	<b>21,73</b>	<i>37,24</i>	<i>37,24</i>	<b>26,27</b>	<b>15,21</b>	<i>37,24</i>	<b>35,44</b>
THE12150	Ø12 x 150	✓										
THE14080	Ø14 x 80	✓	--			--		--		--		
THE14100	Ø14 x 100	✓	--		<b>21,73</b>	--	<i>52,72</i>	--	<b>15,21</b>	--	<b>38,79</b>	
THE14120	Ø14 x 120	✓										
THE14130	Ø14 x 130	✓		<b>43,41</b>	<b>21,73</b>	<i>52,72</i>	<i>52,72</i>	<b>30,39</b>	<b>15,21</b>	<i>52,72</i>	<b>38,79</b>	
THE14140	Ø14 x 140	✓										
THE14160	Ø14 x 160	✓										
THE18100	Ø18 x 100	✓	--			--		--		--		
THE18130	Ø18 x 130	✓	--		<b>28,50</b>	--	<b>75,82</b>	--	<b>19,95</b>	--	<b>53,07</b>	
THE18160	Ø18 x 160	✓										
THE18180	Ø18 x 180	✓		<b>58,31</b>	<b>28,50</b>	<i>80,78</i>	<b>75,82</b>	<b>40,82</b>	<b>19,95</b>	<i>80,78</i>	<b>53,07</b>	
THE18200	Ø18 x 200	✓										

\*Ø5 Approuvé uniquement pour un emploi sur le béton et sur dalles alvéolaires préfabriquées pour des systèmes non-structuraux redondants

Paramètres généraux				Non-fissuré béton				Fissuré béton			
Familie	Code	Dimension	Evaluation	Traction $N_{RK, ucr}$		Cisaillemen $V_{RK, ucr}$		Traction $N_{RK, cr}$		Cisaillemen $V_{RK, cr}$	
			ETA	( $h_{ef, std}$ )	( $h_{ef, red}$ )	( $h_{ef, std}$ )	( $h_{ef, red}$ )	( $h_{ef, std}$ )	( $h_{ef, red}$ )	( $h_{ef, std}$ )	( $h_{ef, red}$ )
TFE	TFE05040	Ø5 x 40	✓*	--	6,71	--	6,71	--	4,70	--	4,70
	TFE05050	Ø5 x 50	✓*								
	TFE05060	Ø5 x 60	✓*								
	TFE05080	Ø5 x 80	✓*	10,19	6,71	<u>8,19</u>	6,71	7,13	4,70	7,13	4,70
	TFE05100	Ø5 x 100	✓*								
	TFE06040	Ø6 x 40	✓	--	5,00	--	<u>12,53</u>	--	4,57	--	9,36
	TFE06050	Ø6 x 50	✓	--				--		--	
	TFE06060	Ø6 x 60	✓								
	TFE06070	Ø6 x 70	✓								
	TFE06080	Ø6 x 80	✓	13,87	5,00	<u>12,53</u>	<u>12,53</u>	9,71	4,57	11,17	9,36
	TFE06100	Ø6 x 100	✓								
	TFE06120	Ø6 x 120	✓								
	TFE08055	Ø8 x 55	✓	--	11,30	--	<u>19,57</u>	--	7,91	--	14,23
	TFE08060	Ø8 x 60	✓	--				--		--	
	TFE08070	Ø8 x 70	✓								
	TFE08080	Ø8 x 80	✓								
	TFE08090	Ø8 x 90	✓								
	TFE08100	Ø8 x 100	✓	17,65	11,30	<u>19,57</u>	<u>19,57</u>	12,36	7,91	15,69	14,23
	TFE08110	Ø8 x 110	✓								
	TFE08120	Ø8 x 120	✓								
	TFE08140	Ø8 x 140	✓								
	TFE10060	Ø10 x 60	✓	--		--		--		--	
	TFE10070	Ø10 x 70	✓	--	13,15	--	25,65	--	9,21	--	17,95
	TFE10080	Ø10 x 80	✓	--		--		--		--	
	TFE10090	Ø10 x 90	✓								
	TFE10100	Ø10 x 100	✓	26,98	13,15	<u>27,40</u>	25,65	18,89	9,21	<u>27,40</u>	17,95
	TFE10120	Ø10 x 120	✓								
	TFE10140	Ø10 x 140	✓								
	TFE12080	Ø12 x 80	✓	--	21,73	--	<u>37,24</u>	--	15,21	--	35,44
	TFE12090	Ø12 x 90	✓	--		--		--		--	
	TFE12110	Ø12 x 110	✓								
	TFE12130	Ø12 x 130	✓	37,54	21,73	<u>37,24</u>	<u>37,24</u>	26,27	15,21	<u>37,24</u>	35,44
TFE12150	Ø12 x 150	✓									
TFE14080	Ø14 x 80	✓	--	21,73	--	<u>52,72</u>	--	15,21	--	38,79	
TFE14100	Ø14 x 100	✓	--		--		--		--		
TFE14120	Ø14 x 120	✓									
TFE14130	Ø14 x 130	✓	43,41	21,73	<u>52,72</u>	<u>52,72</u>	30,39	15,21	<u>52,72</u>	38,79	
TFE14140	Ø14 x 140	✓									
TFE14160	Ø14 x 160	✓									
TFE18100	Ø18 x 100	✓	--	28,50	--	75,82	--	19,95	--	53,07	
TFE18130	Ø18 x 130	✓	--		--		--		--		
TFE18160	Ø18 x 160	✓									
TFE18180	Ø18 x 180	✓	58,31	28,50	<u>80,78</u>	75,82	40,82	19,95	<u>80,78</u>	53,07	
TFE18200	Ø18 x 200	✓									
TFN	TFN14080	Ø14 x 80	✓	--	21,73	--	<u>52,72</u>	--	15,21	--	38,79
THA	THA05040	Ø5 x 40	✓*	--	6,71	--	6,71	--	4,70	--	4,70
	THA05060	Ø5 x 60	✓*								
	THA05080	Ø5 x 80	✓*	10,44	6,88	<u>8,19</u>	6,88	7,45	4,91	7,45	4,91
	THA05100	Ø5 x 100	✓*								
	THA06045	Ø6 x 45	✓	--	5,00	--	<u>12,53</u>	--	4,57	--	9,36
	THA06050	Ø6 x 50	✓	--		--		--		--	
	THA06060	Ø6 x 60	✓								
	THA06080	Ø6 x 80	✓	13,87	5,00	<u>12,53</u>	<u>12,53</u>	9,71	4,57	11,17	9,36
	THA06120	Ø6 x 120	✓								
	THA06140	Ø6 x 140	✓								
	THA08060	Ø8 x 60	✓	--	11,30	--	<u>19,57</u>	--	7,91	--	14,23
	THA08080	Ø8 x 80	✓								
	THA08100	Ø8 x 100	✓	17,65	11,30	<u>19,57</u>	<u>19,57</u>	12,36	7,91	15,69	14,23
	THA08120	Ø8 x 120	✓								
	THA10100	Ø10 x 100	✓	26,98	13,15	<u>27,40</u>	25,65	18,89	9,21	<u>27,40</u>	17,95
	THA10120	Ø10 x 120	✓								

\*Ø5 Approuvé uniquement pour un emploi sur le béton et sur dalles alvéolaires préfabriquées pour des systèmes non-structuraux redondants

Paramètres généraux				Non-fissuré béton				Fissuré béton			
Familie	Code	Dimension	Evaluation	Traction $N_{Rk, ucr}$		Cisaillemen $V_{Rk, ucr}$		Traction $N_{Rk, cr}$		Cisaillemen $V_{Rk, cr}$	
			ETA	( $h_{ef, std}$ )	( $h_{ef, red}$ )	( $h_{ef, std}$ )	( $h_{ef, red}$ )	( $h_{ef, std}$ )	( $h_{ef, red}$ )	( $h_{ef, std}$ )	( $h_{ef, red}$ )
THT	THT06040	Ø6 x 40	✓	--	5,00	--	<u>12,53</u>	--	<b>4,57</b>	--	<b>9,36</b>
	THT06050	Ø6 x 50	✓	--		--		--		--	
	THT06060	Ø6 x 60	✓	<b>13,87</b>	5,00	<u>12,53</u>	<u>12,53</u>	<b>9,71</b>	<b>4,57</b>	<b>11,17</b>	<b>9,36</b>
THP	THP05040	Ø5 x 40	✓*	--	<b>6,71</b>	--	<b>6,71</b>	--	<b>4,70</b>	--	<b>4,70</b>
	THP05060	Ø5 x 60	✓*	<b>10,19</b>	<b>6,71</b>	<u>8,19</u>	<b>6,71</b>	<b>7,13</b>	<b>4,70</b>	<b>7,13</b>	<b>4,70</b>
	THP06040	Ø6 x 40	✓	--	5,00	--	<u>12,53</u>	<b>9,71</b>	<b>4,57</b>	--	<b>9,36</b>
	THP06050	Ø6 x 50	✓	--		--		--		--	
	THP06060	Ø6 x 60	✓								
	THP06080	Ø6 x 80	✓	<b>13,87</b>	5,00	<u>12,53</u>	<u>12,53</u>	<b>9,71</b>	<b>4,57</b>	<b>11,17</b>	<b>9,36</b>
	THP06100	Ø6 x 100	✓								
	THP08060	Ø8 x 60	✓	--	<b>11,30</b>	--	<u>19,57</u>	--	<b>7,91</b>	--	<b>14,23</b>
	THP08080	Ø8 x 80	✓	<b>17,65</b>	<b>11,30</b>	<u>19,57</u>	<u>19,57</u>	<b>12,36</b>	<b>7,91</b>	<b>15,69</b>	<b>14,23</b>
TFF	TFF06035	Ø6 x 35 (M8-M10)	✓	--	5,00	--	--	--	<b>4,77</b>	--	--
	TFF06055	Ø6 x 55 (M8-M10)	✓	<b>13,87</b>	--	--	--	<b>9,71</b>	--	--	--
TFM	TFM06035	Ø6 x 35 (M8)	✓	--	5,00	--	--	--	<b>4,57</b>	--	--
	TFM06055	Ø6 x 55 (M10)	✓	<b>13,87</b>	--	--	--	<b>9,71</b>	--	--	--
TFS	TFS06100	Ø6 x 100 (M8)	✓	<b>13,87</b>	5,00	<u>12,53</u>	<u>12,53</u>	<b>9,71</b>	<b>4,57</b>	<b>11,17</b>	<b>9,36</b>
	TFS06120	Ø6 x 120 (M8)	✓								
	TFS08110	Ø8 x 110 (M10)	✓	<b>17,65</b>	<b>11,30</b>	<u>19,57</u>	<u>19,57</u>	<b>12,36</b>	<b>7,91</b>	<b>15,69</b>	<b>14,23</b>
	TFS08130	Ø8 x 130 (M10)	✓								
	TFS10120	Ø10 x 120 (M12)	✓	<b>22,01</b>	<b>13,15</b>	<u>27,40</u>	<b>25,65</b>	<b>15,41</b>	<b>9,21</b>	<b>20,34</b>	<b>17,95</b>
	TFS10140	Ø10 x 140 (M12)	✓								

\*Ø5 Approuvé uniquement pour un emploi sur le béton et sur dalles alvéolaires préfabriquées pour des systèmes non-structuraux redondants

5.2 RESISTANCES DE CALCUL (APPLICATION STRUCTURELLE) [kN]

Paramètres généraux			Non-fissuré béton				Fissuré béton					
Familie	Code	Dimension	Evaluation	Traction $N_{Rk, ucr}$		Cisaillemen $V_{Rk, ucr}$		Traction $N_{Rk, cr}$		Cisaillemen $V_{Rk, cr}$		
				( $h_{ef, std}$ )	( $h_{ef, red}$ )	( $h_{ef, std}$ )	( $h_{ef, red}$ )	( $h_{ef, std}$ )	( $h_{ef, red}$ )	( $h_{ef, std}$ )	( $h_{ef, red}$ )	
THE	THE05040	Ø5 x 40	✓*	--	4,47	--	4,47	--	3,13	--	3,13	
	THE05050	Ø5 x 50	✓*	6,79	4,47	5,46	4,47	4,75	3,13	4,75	3,13	
	THE05060	Ø5 x 60	✓*									
	THE05080	Ø5 x 80	✓*									
	THE05100	Ø5 x 100	✓*									
	THE06040	Ø6 x 40	✓									--
	THE06050	Ø6 x 50	✓	--	9,25	2,78	8,35	8,35	6,47	2,54	7,44	6,24
	THE06060	Ø6 x 60	✓									
	THE06070	Ø6 x 70	✓									
	THE06080	Ø6 x 80	✓									
	THE06100	Ø6 x 100	✓									
	THE06120	Ø6 x 120	✓	11,77	6,28	13,05	13,05	8,24	4,39	10,46	9,49	
	THE08055	Ø8 x 55	✓									
	THE08060	Ø8 x 60	✓									
	THE08070	Ø8 x 70	✓									
	THE08080	Ø8 x 80	✓									
	THE08090	Ø8 x 90	✓	17,99	8,77	18,27	17,10	12,59	6,14	18,27	11,97	
	THE08100	Ø8 x 100	✓									
	THE08110	Ø8 x 110	✓									
	THE08120	Ø8 x 120	✓									
	THE08140	Ø8 x 140	✓									
	THE10060	Ø10 x 60	✓	--	14,49	24,83	24,83	17,52	10,14	24,83	23,63	
	THE10070	Ø10 x 70	✓									
	THE10080	Ø10 x 80	✓									
	THE10090	Ø10 x 90	✓									
	THE10100	Ø10 x 100	✓									
	THE10120	Ø10 x 120	✓	25,02	14,49	24,83	24,83	17,52	10,14	24,83	23,63	
	THE10140	Ø10 x 140	✓									
	THE12080	Ø12 x 80	✓									
	THE12090	Ø12 x 90	✓									
	THE12110	Ø12 x 110	✓									
	THE12130	Ø12 x 130	✓	28,94	14,49	35,15	35,15	20,26	10,14	35,15	25,86	
THE12150	Ø12 x 150	✓										
THE14080	Ø14 x 80	✓										
THE14100	Ø14 x 100	✓										
THE14120	Ø14 x 120	✓										
THE14130	Ø14 x 130	✓	38,87	19,00	53,85	50,54	27,21	13,30	53,85	35,38		
THE14140	Ø14 x 140	✓										
THE14160	Ø14 x 160	✓										
THE18100	Ø18 x 100	✓										
THE18130	Ø18 x 130	✓										
THE18160	Ø18 x 160	✓										
THE18180	Ø18 x 180	✓										
THE18200	Ø18 x 200	✓										

\*Ø5 Approuvé uniquement pour un emploi sur le béton et sur dalles alvéolaires préfabriquées pour des systèmes non-structuraux redondants



Paramètres généraux				Non-fissuré béton				Fissuré béton				
Familie	Code	Dimension	Evaluation	Traction $N_{Rk, ucr}$		Cisaillemen $V_{Rk, ucr}$		Traction $N_{Rk, cr}$		Cisaillemen $V_{Rk, cr}$		
			ETA	( $h_{ef, sta}$ )	( $h_{ef, red}$ )	( $h_{ef, sta}$ )	( $h_{ef, red}$ )	( $h_{ef, sta}$ )	( $h_{ef, red}$ )	( $h_{ef, sta}$ )	( $h_{ef, red}$ )	
TFE	TFE05040	Ø5 x 40	✓*	--	4,47	--	4,47	--	3,13	--	3,13	
	TFE05050	Ø5 x 50	✓*									
	TFE05060	Ø5 x 60	✓*									
	TFE05080	Ø5 x 80	✓*		6,79	4,47	<u>5,46</u>	4,47	4,75	3,13	4,75	3,13
	TFE05100	Ø5 x 100	✓*									
	TFE06040	Ø6 x 40	✓		--		--		--		--	
	TFE06050	Ø6 x 50	✓		--	2,78	--	<u>8,35</u>	--	2,54	--	6,24
	TFE06060	Ø6 x 60	✓									
	TFE06070	Ø6 x 70	✓									
	TFE06080	Ø6 x 80	✓									
	TFE06100	Ø6 x 100	✓									
	TFE06120	Ø6 x 120	✓									
	TFE08055	Ø8 x 55	✓		--		--		--		--	
	TFE08060	Ø8 x 60	✓		--	6,28	--	<u>13,05</u>	--	4,39	--	9,49
	TFE08070	Ø8 x 70	✓									
	TFE08080	Ø8 x 80	✓									
	TFE08090	Ø8 x 90	✓									
	TFE08100	Ø8 x 100	✓									
	TFE08110	Ø8 x 110	✓									
	TFE08120	Ø8 x 120	✓									
	TFE08140	Ø8 x 140	✓									
	TFE10060	Ø10 x 60	✓		--		--		--		--	
	TFE10070	Ø10 x 70	✓		--	8,77	--	17,10	--	6,14	--	11,97
	TFE10080	Ø10 x 80	✓									
	TFE10090	Ø10 x 90	✓									
	TFE10100	Ø10 x 100	✓									
	TFE10120	Ø10 x 120	✓									
	TFE10140	Ø10 x 140	✓									
	TFE12080	Ø12 x 80	✓		--		--		--		--	
	TFE12090	Ø12 x 90	✓		--	14,49	--	<u>24,83</u>	--	10,14	--	23,63
	TFE12110	Ø12 x 110	✓									
	TFE12130	Ø12 x 130	✓									
TFE12150	Ø12 x 150	✓										
TFE14080	Ø14 x 80	✓		--		--		--		--		
TFE14100	Ø14 x 100	✓		--	14,49	--	<u>35,15</u>	--	10,14	--	25,86	
TFE14120	Ø14 x 120	✓										
TFE14130	Ø14 x 130	✓										
TFE14140	Ø14 x 140	✓										
TFE14160	Ø14 x 160	✓										
TFE18100	Ø18 x 100	✓		--		--		--		--		
TFE18130	Ø18 x 130	✓		--	19,00	--	50,54	--	13,30	--	35,38	
TFE18160	Ø18 x 160	✓										
TFE18180	Ø18 x 180	✓										
TFE18200	Ø18 x 200	✓										
TFN	TFN14080	Ø14 x 80	✓	--	14,49	--	35,15	--	10,14	--	25,86	
THA	THA05040	Ø5 x 40	✓*	--	4,47	--	4,47	--	3,13	--	3,13	
	THA05060	Ø5 x 60	✓*									
	THA05080	Ø5 x 80	✓*		6,79	4,47	<u>5,46</u>	4,47	4,75	3,13	4,75	3,13
	THA05100	Ø5 x 100	✓*									
	THA06045	Ø6 x 45	✓		--		--		--		--	
	THA06050	Ø6 x 50	✓		--	2,78	--	<u>8,35</u>	--	2,54	--	6,24
	THA06060	Ø6 x 60	✓									
	THA06080	Ø6 x 80	✓									
	THA06120	Ø6 x 120	✓									
	THA06140	Ø6 x 140	✓									
	THA08060	Ø8 x 60	✓		--		--		--		--	
	THA08080	Ø8 x 80	✓									
	THA08100	Ø8 x 100	✓									
	THA08120	Ø8 x 120	✓									
	THA10100	Ø10 x 100	✓									
	THA10120	Ø10 x 120	✓									

\*Ø5 Approuvé uniquement pour un emploi sur le béton et sur dalles alvéolaires préfabriquées pour des systèmes non-structuraux redondants

Paramètres généraux				Non-fissuré béton				Fissuré béton			
Familie	Code	Dimension	Evaluation	Traction $N_{Rk, ucr}$		Cisaillemen $V_{Rk, ucr}$		Traction $N_{Rk, cr}$		Cisaillemen $V_{Rk, cr}$	
			ETA								
THT	THT06040	Ø6 x 40	✓	--	2,78	--	<u>8,35</u>	--	2,54	--	6,24
	THT06050	Ø6 x 50	✓	--		--		--		--	
	THT06060	Ø6 x 60	✓	9,25	2,78	<u>8,35</u>	<u>8,35</u>	6,47	2,54	7,44	6,24
THP	THP05040	Ø5 x 40	✓*	--	4,47	--	4,47	--	3,13	--	3,13
	THP05060	Ø5 x 60	✓*	6,79	4,47	<u>5,46</u>	4,47	4,75	3,13	4,75	3,13
	THP06040	Ø6 x 40	✓	--	2,78	--	<u>8,35</u>	--	2,54	--	6,24
	THP06050	Ø6 x 50	✓	--		--		--		--	
	THP06060	Ø6 x 60	✓								
	THP06080	Ø6 x 80	✓	9,25	2,78	<u>8,35</u>	<u>8,35</u>	6,47	2,54	7,44	6,24
	THP06100	Ø6 x 100	✓								
	THP08060	Ø8 x 60	✓	--	6,28	--	<u>13,05</u>	--	4,39	--	9,49
	THP08080	Ø8 x 80	✓	11,77	6,28	<u>13,05</u>	<u>13,05</u>	8,24	4,39	10,46	9,49
TFF	TFF06035	Ø6 x 35 (M8-M10)	✓	--	2,78	--	--	--	2,54	--	--
	TFF06055	Ø6 x 55 (M8-M10)	✓	9,25	--	--	--	6,47	--	--	--
TFM	TFM06035	Ø6 x 35 (M8)	✓	--	2,78	--	--	--	2,54	--	--
	TFM06055	Ø6 x 55 (M10)	✓	9,25	--	--	--	6,47	--	--	--
TFS	TFS06100	Ø6 x 100 (M8)	✓								
	TFS06120	Ø6 x 120 (M8)	✓	9,25	2,78	<u>8,35</u>	<u>8,35</u>	6,47	2,54	7,44	6,24
	TFS08110	Ø8 x 110 (M10)	✓								
	TFS08130	Ø8 x 130 (M10)	✓	11,77	6,28	<u>13,05</u>	<u>13,05</u>	8,24	4,39	10,46	9,49
	TFS10120	Ø10 x 120 (M12)	✓								
	TFS10140	Ø10 x 140 (M12)	✓	14,67	8,77	<u>18,27</u>	17,10	10,27	6,14	13,56	11,97

\*Ø5 Approuvé uniquement pour un emploi sur le béton et sur dalles alvéolaires préfabriquées pour des systèmes non-structuraux redondants

**5.3 CHARGES MAXIMALES RECOMMANDÉES (APPLICATION STRUCTURELLE) [kN] (avec  $\gamma_F=1.4$ )**

Paramètres généraux			Non-fissuré béton				Fissuré béton				
Familie	Code	Dimension	Evaluation	Traction $N_{Rk,ucr}$		Cisaillemen $V_{Rk,ucr}$		Traction $N_{Rk,cr}$		Cisaillemen $V_{Rk,cr}$	
				( $h_{ef, std}$ )	( $h_{ef, red}$ )	( $h_{ef, std}$ )	( $h_{ef, red}$ )	( $h_{ef, std}$ )	( $h_{ef, red}$ )	( $h_{ef, std}$ )	( $h_{ef, red}$ )
THE	THE05040	Ø5 x 40	✓*	--	<b>3,20</b>	--	<b>3,20</b>	--	<b>2,24</b>	--	<b>2,24</b>
	THE05050	Ø5 x 50	✓*	<b>4,85</b>	<b>3,20</b>	<u>3,90</u>	<b>3,20</b>	<b>3,40</b>	<b>2,24</b>	<b>3,40</b>	<b>2,24</b>
	THE05060	Ø5 x 60	✓*								
	THE05080	Ø5 x 80	✓*								
	THE05100	Ø5 x 100	✓*								
	THE06040	Ø6 x 40	✓								
	THE06050	Ø6 x 50	✓	<b>6,61</b>	1,98	<u>5,97</u>	<u>5,97</u>	<b>4,62</b>	<b>1,81</b>	<b>5,32</b>	<b>4,46</b>
	THE06060	Ø6 x 60	✓								
	THE06070	Ø6 x 70	✓								
	THE06080	Ø6 x 80	✓								
	THE06100	Ø6 x 100	✓								
	THE06120	Ø6 x 120	✓	<b>8,41</b>	<b>4,48</b>	<u>9,32</u>	<u>9,32</u>	<b>5,88</b>	<b>3,14</b>	<b>7,47</b>	<b>6,78</b>
	THE08055	Ø8 x 55	✓								
	THE08060	Ø8 x 60	✓								
	THE08070	Ø8 x 70	✓								
	THE08080	Ø8 x 80	✓								
	THE08090	Ø8 x 90	✓	<b>12,85</b>	<b>6,26</b>	<u>13,05</u>	<b>12,21</b>	<b>8,99</b>	<b>4,38</b>	<u>13,05</u>	<b>8,55</b>
	THE08100	Ø8 x 100	✓								
	THE08110	Ø8 x 110	✓								
	THE08120	Ø8 x 120	✓								
	THE08140	Ø8 x 140	✓								
	THE10060	Ø10 x 60	✓	<b>17,87</b>	<b>10,35</b>	<u>17,73</u>	<u>17,73</u>	<b>12,51</b>	<b>7,24</b>	<u>17,73</u>	<b>16,88</b>
	THE10070	Ø10 x 70	✓								
	THE10080	Ø10 x 80	✓								
	THE10090	Ø10 x 90	✓								
	THE10100	Ø10 x 100	✓								
	THE10120	Ø10 x 120	✓	<b>20,67</b>	<b>10,35</b>	<u>25,10</u>	<u>25,10</u>	<b>14,47</b>	<b>7,24</b>	<u>25,10</u>	<b>18,47</b>
	THE10140	Ø10 x 140	✓								
	THE12080	Ø12 x 80	✓								
	THE12090	Ø12 x 90	✓								
	THE12110	Ø12 x 110	✓								
	THE12130	Ø12 x 130	✓	<b>27,77</b>	<b>13,57</b>	<u>38,47</u>	<b>36,10</b>	<b>19,44</b>	<b>9,50</b>	<u>38,47</u>	<b>25,27</b>
THE12150	Ø12 x 150	✓									
THE14080	Ø14 x 80	✓									
THE14100	Ø14 x 100	✓									
THE14120	Ø14 x 120	✓									
THE14130	Ø14 x 130	✓	<b>27,77</b>	<b>13,57</b>	<u>38,47</u>	<b>36,10</b>	<b>19,44</b>	<b>9,50</b>	<u>38,47</u>	<b>25,27</b>	
THE14140	Ø14 x 140	✓									
THE14160	Ø14 x 160	✓									
THE18100	Ø18 x 100	✓									
THE18130	Ø18 x 130	✓									
THE18160	Ø18 x 160	✓	<b>27,77</b>	<b>13,57</b>	<u>38,47</u>	<b>36,10</b>	<b>19,44</b>	<b>9,50</b>	<u>38,47</u>	<b>25,27</b>	
THE18180	Ø18 x 180	✓									
THE18200	Ø18 x 200	✓									

\*Ø5 Approuvé uniquement pour un emploi sur le béton et sur dalles alvéolaires préfabriquées pour des systèmes non-structuraux redondants

Paramètres généraux				Non-fissuré béton				Fissuré béton			
Familie	Code	Dimension	Evaluation	Traction $N_{Rk, ucr}$		Cisaillemen $V_{Rk, ucr}$		Traction $N_{Rk, cr}$		Cisaillemen $V_{Rk, cr}$	
			ETA	( $h_{ef, std}$ )	( $h_{ef, red}$ )	( $h_{ef, std}$ )	( $h_{ef, red}$ )	( $h_{ef, std}$ )	( $h_{ef, red}$ )	( $h_{ef, std}$ )	( $h_{ef, red}$ )
TFE	TFE05040	Ø5 x 40	✓*	--	<b>3,20</b>	--	<b>3,20</b>	--	<b>2,24</b>	--	<b>2,24</b>
	TFE05050	Ø5 x 50	✓*								
	TFE05060	Ø5 x 60	✓*								
	TFE05080	Ø5 x 80	✓*	<b>4,85</b>	<b>3,20</b>	<u>3,90</u>	<b>3,20</b>	<b>3,40</b>	<b>2,24</b>	<b>3,40</b>	<b>2,24</b>
	TFE05100	Ø5 x 100	✓*								
	TFE06040	Ø6 x 40	✓	--		--	<u>5,97</u>	--	<b>1,81</b>	--	<b>4,46</b>
	TFE06050	Ø6 x 50	✓	--	1,98	--	<u>5,97</u>	--	<b>1,81</b>	--	<b>4,46</b>
	TFE06060	Ø6 x 60	✓								
	TFE06070	Ø6 x 70	✓								
	TFE06080	Ø6 x 80	✓	<b>6,61</b>	1,98	<u>5,97</u>	<u>5,97</u>	<b>4,62</b>	<b>1,81</b>	<b>5,32</b>	<b>4,46</b>
	TFE06100	Ø6 x 100	✓								
	TFE06120	Ø6 x 120	✓								
	TFE08055	Ø8 x 55	✓	--		--	<u>9,32</u>	--	<b>3,14</b>	--	<b>6,78</b>
	TFE08060	Ø8 x 60	✓	--	<b>4,48</b>	--	<u>9,32</u>	--	<b>3,14</b>	--	<b>6,78</b>
	TFE08070	Ø8 x 70	✓								
	TFE08080	Ø8 x 80	✓								
	TFE08090	Ø8 x 90	✓								
	TFE08100	Ø8 x 100	✓	<b>8,41</b>	<b>4,48</b>	<u>9,32</u>	<u>9,32</u>	<b>5,88</b>	<b>3,14</b>	<b>7,47</b>	<b>6,78</b>
	TFE08110	Ø8 x 110	✓								
	TFE08120	Ø8 x 120	✓								
	TFE08140	Ø8 x 140	✓								
	TFE10060	Ø10 x 60	✓	--		--		--		--	
	TFE10070	Ø10 x 70	✓	--	<b>6,26</b>	--	<b>12,21</b>	--	<b>4,38</b>	--	<b>8,55</b>
	TFE10080	Ø10 x 80	✓	--		--		--		--	
	TFE10090	Ø10 x 90	✓								
	TFE10100	Ø10 x 100	✓	<b>12,85</b>	<b>6,26</b>	<u>13,05</u>	<b>12,21</b>	<b>8,99</b>	<b>4,38</b>	<u>13,05</u>	<b>8,55</b>
	TFE10120	Ø10 x 120	✓								
	TFE10140	Ø10 x 140	✓								
	TFE12080	Ø12 x 80	✓	--		--	<u>17,73</u>	--	<b>7,24</b>	--	<b>16,88</b>
	TFE12090	Ø12 x 90	✓	--	<b>10,35</b>	--	<u>17,73</u>	--	<b>7,24</b>	--	<b>16,88</b>
	TFE12110	Ø12 x 110	✓								
	TFE12130	Ø12 x 130	✓	<b>17,87</b>	<b>10,35</b>	<u>17,73</u>	<u>17,73</u>	<b>12,51</b>	<b>7,24</b>	<u>17,73</u>	<b>16,88</b>
TFE12150	Ø12 x 150	✓									
TFE14080	Ø14 x 80	✓	--		--	<u>25,10</u>	--	<b>7,24</b>	--	<b>18,47</b>	
TFE14100	Ø14 x 100	✓	--	<b>10,35</b>	--	<u>25,10</u>	--	<b>7,24</b>	--	<b>18,47</b>	
TFE14120	Ø14 x 120	✓									
TFE14130	Ø14 x 130	✓	<b>20,67</b>	<b>10,35</b>	<u>25,10</u>	<u>25,10</u>	<b>14,47</b>	<b>7,24</b>	<u>25,10</u>	<b>18,47</b>	
TFE14140	Ø14 x 140	✓									
TFE14160	Ø14 x 160	✓									
TFE18100	Ø18 x 100	✓	--		--	<b>36,10</b>	--	<b>9,50</b>	--	<b>25,27</b>	
TFE18130	Ø18 x 130	✓	--	<b>13,57</b>	--	<b>36,10</b>	--	<b>9,50</b>	--	<b>25,27</b>	
TFE18160	Ø18 x 160	✓									
TFE18180	Ø18 x 180	✓	<b>27,77</b>	<b>13,57</b>	<u>38,47</u>	<b>36,10</b>	<b>20,26</b>	<b>9,50</b>	<u>38,47</u>	<b>25,27</b>	
TFE18200	Ø18 x 200	✓									
TFN	TFN14080	Ø14 x 80	✓	--	<b>10,35</b>	--	<b>25,10</b>	--	<b>7,24</b>	--	<b>18,47</b>
THA	THA05040	Ø5 x 40	✓*	--	<b>3,20</b>	--	<b>3,20</b>	--	<b>2,24</b>	--	<b>2,24</b>
	THA05060	Ø5 x 60	✓*								
	THA05080	Ø5 x 80	✓*	<b>4,85</b>	<b>3,20</b>	<u>3,90</u>	<b>3,20</b>	<b>3,40</b>	<b>2,24</b>	<b>3,40</b>	<b>2,24</b>
	THA05100	Ø5 x 100	✓*								
	THA06045	Ø6 x 45	✓	--		--	<u>5,97</u>	--	<b>1,81</b>	--	<b>4,46</b>
	THA06050	Ø6 x 50	✓	--	1,98	--	<u>5,97</u>	--	<b>1,81</b>	--	<b>4,46</b>
	THA06060	Ø6 x 60	✓								
	THA06080	Ø6 x 80	✓	<b>6,61</b>	1,98	<u>5,97</u>	<u>5,97</u>	<b>4,62</b>	<b>1,81</b>	<b>5,32</b>	<b>4,46</b>
	THA06120	Ø6 x 120	✓								
	THA06140	Ø6 x 140	✓								
	THA08060	Ø8 x 60	✓	--	<b>4,48</b>	--	<u>9,32</u>	--	<b>3,14</b>	--	<b>6,78</b>
	THA08080	Ø8 x 80	✓								
	THA08100	Ø8 x 100	✓	<b>8,41</b>	<b>4,48</b>	<u>9,32</u>	<u>9,32</u>	<b>5,88</b>	<b>3,14</b>	<b>7,47</b>	<b>6,78</b>
	THA08120	Ø8 x 120	✓								
	THA10100	Ø10 x 100	✓	<b>12,85</b>	<b>6,26</b>	<u>13,05</u>	<b>12,21</b>	<b>8,99</b>	<b>4,38</b>	<u>13,05</u>	<b>8,55</b>
THA10120	Ø10 x 120	✓									

\*Ø5 Approuvé uniquement pour un emploi sur le béton et sur dalles alvéolaires préfabriquées pour des systèmes non-structuraux redondants

Paramètres généraux				Non-fissuré béton				Fissuré béton			
Familie	Code	Dimension	Evaluation	Traction $N_{Rk,ucr}$		Cisaillemen $V_{Rk,ucr}$		Traction $N_{Rk,cr}$		Cisaillemen $V_{Rk,cr}$	
			ETA	( $h_{ef, std}$ )	( $h_{ef, red}$ )	( $h_{ef, std}$ )	( $h_{ef, red}$ )	( $h_{ef, std}$ )	( $h_{ef, red}$ )	( $h_{ef, std}$ )	( $h_{ef, red}$ )
THT	THT06040	Ø6 x 40	✓	--	1,98	--	<u>5,97</u>	--	<b>1,81</b>	--	<b>4,46</b>
	THT06050	Ø6 x 50	✓	--	1,98	--	<u>5,97</u>	--	<b>1,81</b>	--	<b>4,46</b>
	THT06060	Ø6 x 60	✓	<b>6,61</b>	1,98	<u>5,97</u>	<u>5,97</u>	<b>4,62</b>	<b>1,81</b>	<b>5,32</b>	<b>4,46</b>
THP	THP05040	Ø5 x 40	✓*	--	<b>3,20</b>	--	<b>3,20</b>	--	<b>2,24</b>	--	<b>2,24</b>
	THP05060	Ø5 x 60	✓*	<b>4,85</b>	<b>3,20</b>	<u>3,90</u>	<b>3,20</b>	<b>3,40</b>	<b>2,24</b>	<b>3,40</b>	<b>2,24</b>
	THP06040	Ø6 x 40	✓	--	1,98	--	<u>5,97</u>	--	<b>1,81</b>	--	<b>4,46</b>
	THP06050	Ø6 x 50	✓	--	1,98	--	<u>5,97</u>	--	<b>1,81</b>	--	<b>4,46</b>
	THP06060	Ø6 x 60	✓	--	1,98	--	<u>5,97</u>	--	<b>1,81</b>	--	<b>4,46</b>
	THP06080	Ø6 x 80	✓	<b>6,61</b>	1,98	<u>5,97</u>	<u>5,97</u>	<b>4,62</b>	<b>1,81</b>	<b>5,32</b>	<b>4,46</b>
	THP06100	Ø6 x 100	✓	--	1,98	--	<u>5,97</u>	--	<b>1,81</b>	--	<b>4,46</b>
	THP08060	Ø8 x 60	✓	--	<b>4,48</b>	--	<u>9,32</u>	--	<b>3,14</b>	--	<b>6,78</b>
	THP08080	Ø8 x 80	✓	<b>8,41</b>	<b>4,48</b>	<u>9,32</u>	<u>9,32</u>	<b>5,88</b>	<b>3,14</b>	<b>7,47</b>	<b>6,78</b>
TFF	TFF06035	Ø6 x 35 (M8-M10)	✓	--	1,98	--	--	--	<b>1,81</b>	--	--
	TFF06055	Ø6 x 55 (M8-M10)	✓	<b>6,61</b>	--	--	--	<b>4,62</b>	--	--	--
TFM	TFM06035	Ø6 x 35 (M8)	✓	--	1,98	--	--	--	<b>1,81</b>	--	--
	TFM06055	Ø6 x 55 (M10)	✓	<b>6,61</b>	--	--	--	<b>4,62</b>	--	--	--
TFS	TFS06100	Ø6 x 100 (M8)	✓	<b>6,61</b>	1,98	<u>5,97</u>	<u>5,97</u>	<b>4,62</b>	<b>1,81</b>	<b>5,32</b>	<b>4,46</b>
	TFS06120	Ø6 x 120 (M8)	✓	--	1,98	--	--	--	<b>1,81</b>	--	--
	TFS08110	Ø8 x 110 (M10)	✓	<b>8,41</b>	<b>4,48</b>	<u>9,32</u>	<u>9,32</u>	<b>5,88</b>	<b>3,14</b>	<b>7,47</b>	<b>6,78</b>
	TFS08130	Ø8 x 130 (M10)	✓	--	<b>4,48</b>	--	--	--	<b>3,14</b>	--	--
	TFS10120	Ø10 x 120 (M12)	✓	<b>10,48</b>	<b>6,26</b>	<u>13,05</u>	<b>12,21</b>	<b>7,34</b>	<b>4,38</b>	<b>9,68</b>	<b>8,55</b>
TFS10140	Ø10 x 140 (M12)	✓	--	<b>6,26</b>	--	--	--	<b>4,38</b>	--	--	

\*Ø5 Approuvé uniquement pour un emploi sur le béton et sur dalles alvéolaires préfabriquées pour des systèmes non-structuraux redondants

**COEFFICIENT DE MAJORATION A EXTRACTION  
POUR CHARGES A TRACTION DANS DU BÉTON HAUTE RÉSISTANCE  $\psi_c$**

Diamètre	Ø5		Ø6		Ø8		Ø10			Ø12		Ø14		Ø18	
	( $h_{ef, red}$ )	( $h_{ef, std}$ )	( $h_{ef, red}$ )	( $h_{ef, std}$ )	( $h_{ef, red}$ )	( $h_{ef, std}$ )	( $h_{ef, 1}$ )	( $h_{ef, 2}$ )	( $h_{ef, 3}$ )	( $h_{ef, red}$ )	( $h_{ef, std}$ )	( $h_{ef, red}$ )	( $h_{ef, std}$ )	( $h_{ef, red}$ )	( $h_{ef, std}$ )
<b>C30/37</b>	1,00	1,00	1,16	1,22	1,21	1,22	1,22	1,17	1,22	1,16	1,22	1,21	1,20	1,22	1,17
<b>C40/50</b>	1,00	1,00	1,28	1,41	1,39	1,41	1,41	1,30	1,41	1,29	1,41	1,39	1,37	1,40	1,32
<b>C50/60</b>	1,00	1,00	1,39	1,58	1,54	1,58	1,58	1,42	1,58	1,40	1,58	1,55	1,51	1,57	1,42

**6. DOCUMENTATION OFFICIELLE**

Par l'intermédiaire de notre service commercial ou de notre site web [www.indexfix.com](http://www.indexfix.com), vous pouvez obtenir les documents suivants :

- Evaluation européen ETA 20/0046 pour l'installation dans du béton non fissuré selon le guide EAD 330232-00-0601, option 1, de Ø6 à Ø18.
- Evaluation européen ETA 20/0494 pour l'installation dans le béton et sur dalles alvéolaires préfabriquées selon le guide EAD 330747-00-0601, option 1, de Ø6 à Ø18.
- Déclaration of performance DoP THE.
- Certificat VdS CEA 4001 :2021-01(07) *Guidelines for sprinklers systems. Planning and installation for applications of water extinguishing systems on concrete elements* de Ø6 à Ø18
- Disponible pour le programme de calcul des ancrs INDEXcal.